

**Overview**

- Dimmable Constant voltage
- Active power factor correction
- Compliant to IEC623860-101,102,207
- 2-100% Dimming range
- Nominal life 50,000 hours
- 5-year guarantee
- Australia/New Zealand Certification



**Ordering Information**

**Part Number:**

**HDL-CV-300-24-HPF**



**Electrical**

Input:

- 240V, 50Hz
- Power Factor >0.95 @ full load
- Flex: 1M 0.75mm<sup>2</sup> 3 core c/w plug top
- THD: <15%
- Dielectric strength: 3000V
- Inrush current: tba
- Earth leakage current: tba
- MCB B curve: (6A, 10A, 16A) tba
- MCB C curve: (6A, 10A, 16A) tba

**Electrical**

Output:

- 300W, 24V, 12500mA
- Flex: 0.2M 1.5 mm<sup>2</sup> 2 core
- ≥ 90% efficiency @ full load
- 2-100% dimming range

**Mechanical**

- Extruded aluminium housing
- Epoxy Potted
- Dimensions (mm): 250 x 72 x 42
- Weight (grammes): 1300

## PRODUCT DATASHEET

### IP67 DALI Outdoor Series

### 300W 24V CONSTANT VOLTAGE HPF

#### Line Drawing

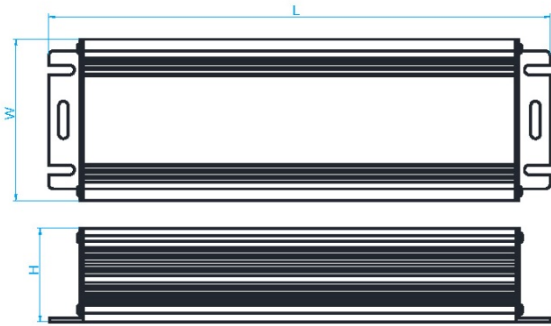

#### Protection

- Class II
- IP67 protection rating
- Fully isolated (input/output)
- Short circuit with auto reset
- Over-voltage with auto reset
- Over-temperature with auto reset

#### Safety

- RCM Mark applied

#### Wiring Diagram

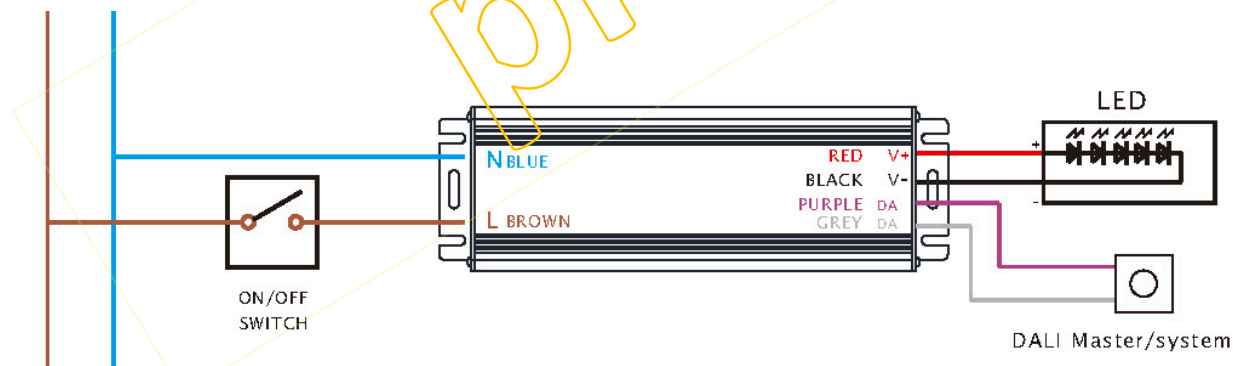

#### Thermal

- Ta rating -30°C to +45°C